

# DH-TPC-SD5600-T

## Thermal Network Speed Dome Camera



- 640x512 VOx uncooled thermal sensor technology
- Athermalized Lens (thermal), Focus-free
- Support temperature measurement
- Support Fire detection & alarm
- Max 240°/s pan speed, 360° endless pan rotation
- Up to 300 presets, 5 auto scan, 8 tour, 5 pattern
- 2/1 alarm in/out
- Micro SD memory, IP66, PoE+



### System Overview

Featuring a fixed lens speed dome camera, this series provides an all-in-one solution for capturing long distance video surveillance for outdoor applications. Together with Thermal technology, the camera's long range capabilities are able to be utilized even at night.

### Functions

#### Uncooled Vox Technology

Dahua thermal cameras use uncooled Vox sensor technology. Their small size and better performance make them a cost-effective solution for thermal security.

#### High Sensitivity

High thermal sensitivity (<40mK) allows camera to capture more image details and temperature difference information.

#### Fire Detection & Alarm

With built-in fire detection functionality, the camera has the ability to detect fires from long range. Because thermal cameras are sensitive to temperature, they provide higher fire detection accuracy than standard cameras, making them particularly fit for applications such as forest fire prevention.

#### Temperature Measurement

Dahua thermal cameras (-T models) provide remote temperature monitoring functionality with the ability to set temperature threshold alarms. Object temperatures can be monitored in daytime or at night, making them ideal for usage in power plant or oil extraction applications where overheating can be dangerous. When the temperature exceeds the set threshold, an alarm is triggered. The temperature range is between -40 °C to 550 °C (-40 °F to 1022 °F).

#### Auto-tracking

This feature controls the pan/tilt/zoom actions of the camera to automatically track an object in motion and to keep it in the scene. The tracking action can be triggered manually or automatically by defined rules. Once a rule is triggered, the camera can zoom in and track the defined target automatically.

#### Environmental

With a temperature range of -40 °C to +60 °C (-40 °F to +140 °F), the camera is designed for extreme temperature environments. Subjected and certified to rigorous dust and water immersion tests, the IP66 rating makes it suitable for demanding outdoor applications.

#### Protection

The camera allows for ±15% input voltage tolerance, suitable for the most unstable conditions for outdoor applications. Its 6KV lightning rating provides effective protection for both the camera and its structure against lightning.

## Technical Specification

### Thermal Camera

Image Sensor	Uncooled VOx Microbolometer
Effective Pixels	640(H)x512(V)
Pixel Size	17um
Thermal Sensitivity (NETD)	<40mK@f/1.0
Spectral Range	7~14um
Image Setting	Brightness/Sharpness/ROI/AGC/FFC/3D DNR
Color Palettes	14(Whitehot/Blackhot/Ironrow/Icefire/Fusion/Rainbow/Globow/Iconbow1/Iconbow2...etc)

### Thermal Lens

Lens Type	Fixed	
Focus Control	Athermalized, Focus-free	
Focal Length	13mm	19mm
Angle of View	H: 45° V: 37°	H: 32° V: 26°
Effective Distance <sup>①</sup> Man(1.8m*0.5m)	D <sup>②</sup> : 450m R <sup>③</sup> : 110m I <sup>④</sup> : 60m	D: 640m R: 160m I: 80m
Effective Distance Vehicle(2.3m*2.3m)	D: 1300m R: 350m I: 180m	D: 2000m R: 500m I: 250m

### PTZ

Pan/Tilt Range	Pan: 0° ~ 360° endless; Tilt: -15° ~ 90°
Manual Control Speed	Pan: 0.1° ~ 200° /s; Tilt: 0.1° ~ 120° /s
Preset Speed	Pan: 0.1° ~ 240° /s; Tilt: 0.1° ~ 120° /s
Preset	300
PTZ Mode	5 Auto Scan, 8 Tour, 5 Pattern, Auto Pan
Speed Setup	Human-oriented focal length/speed adaptation
Power Up Action	Auto restore to previous PTZ and lens status after power failure
Idle Motion	Activate Preset/Scan/Tour/Pattern if there is no command in the specified period
Protocol	DH-SD, Pelco-P/D (Auto recognition)

### Video

Compression	H.264/MJPEG
Frame Rate	Main Stream: 1280*1024 (default)/720P @1 ~ 25/30fps  Sub Stream: 640*512 (default)/320*256 @1 ~ 25/30fps
Bit Rate Control	CBR/VBR
Bit Rate	H.264: 640 ~ 8192Kbps

Motion Detection	Off/On (4 zone, Rectangle)
Region of Interest	Off/On (4 zone)
Electronic Image Stabilization (EIS)	NA
Digital Zoom	24x
Flip	180°
Mirror	Off/On
Privacy Masking	Off/On (4 area, Rectangle)

### Temperature Measurement

Measurement Range	Low Gain: -40°C ~ +550°C High Gain: -40°C ~ +160°C
Measurement Accuracy	Max (±2°C, ±2%)
Measurement Mode	Spot/Line/Area
Measurement Rules	Spot: 12 Line: 12 Area: 12 Support 12 rules per preset simultaneously

### Audio

Compression	G.711a/G.711Mu/AAC
-------------	--------------------

### Intelligence

IVS	Tripwire, Intrusion, Object Abandon/Missing
Advanced Intelligent Functions	Fire detection & alarm, Auto Tracking
Tracking Trigger Mode	Manual/Auto (alarm triggered)
Tracking Trigger Event	Targeting, Zoom, Tracking, Recording, Snapshot, Alarm and etc.

### Network

Ethernet	RJ-45 (10/100Base-T)
Protocol	IPv4/IPv6, HTTP, HTTPS, SSL, TCP/IP, UDP, UPnP, ICMP, IGMP, SNMP, RTSP, RTP, SMTP, NTP, DHCP, DNS, PPPOE, DDNS, FTP, IP Filter, QoS, Bonjour, 802.1x
Interoperability	ONVIF Profile S & G, PSIA, CGI
Streaming Method	Unicast/Multicast
Max. User Access	10 Users/20 Users
Edge Storage	micro SD (128GB) Memory status display (Normal/Error/Active/Formatting/Lock), NAS (Network Attached Storage), Local PC for instant recording
Web Viewer	<IE11, <Chrome45, <Firefox52
Management Software	Smart PSS, DSS
Smart Phone	Android, ios

Certifications

Certification	CE (EN 60950:2000) FCC (FCC Part 15 SubpartB)
---------------	---

Interface

Video Interface	1.0Vp-p/75Ω, PAL/NTSC (HDCVI Optional)
Audio Interface	Input/Output 1/1
RS485	Support
Alarm	2/1 In/Out

Electrical

Power Supply	24V AC/PoE+
Power Consumption	Max. 17W

Environmental

Operating Condition	-40°C ~ +60°C (-40°F ~ +140°F)/Less than 95% RH * Start up should be done at above -40°C (-40°F)
Storage Conditions	-40°C ~ +70°C (-40°F ~ +158°F)/Less than 95% RH
Ingress Protection	IP66

Construction

Casing	Metal
Dimensions	Φ186mm x 491mm (Φ7.32" x 13.71")
Net Weight	3.5Kg (7.72 lb)
Gross Weight	5.9Kg (13 lb)

Note:

- ① Effective distance values shown are nominal values and should be used as estimates only. Exact value calculations depend on a wide variety of conditions.
- ② D: Detection Distance
- ③ R: Recognition Distance
- ④ I: Identification Distance

Ordering Information

Type	Part Number	Description
DH-TPC-SD5600-T	DH-TPC-SD5600P-TA13 DH-TPC-SD5600N-TA13	Thermal: 640x512 13mm lens Temperature measurement
	DH-TPC-SD5600P-TA19 DH-TPC-SD5600N-TA19	Thermal: 640x512 19mm lens Temperature measurement

Accessories

Included:



PFB300S  
Wall Mount



PFA110  
Mount Adapter



AC24V/3A  
Power Supply

Optional:



PFA140  
Power box



PFB300C  
Ceiling Mount



PFA120  
Junction Box



PFA150  
Pole Mount

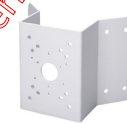

PFA151  
Corner Mount



PFB303S  
Parapet Mount

Mounting Type

Ceiling Mount	Junction Mount
PFA110 + PFB300C	PFA110 + PFB300S + PFA120
Power Box Mount	Pole Mount
PFA110 + PFB300S + PFA140	PFA110 + PFB300S + PFA150
Corner Mount	Parapet Mount
PFA110 + PFB300S + PFA151	PFA110 + PFB303S

Dimensions(mm)

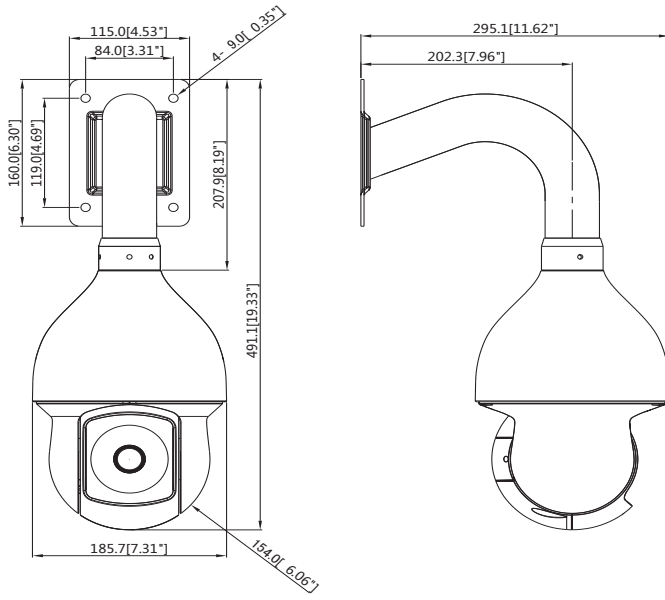

<https://www.e-camere.ro/supraveghere-video/camere/Dahua/camera-ip-ternala-exterior-poe-dahua-tpc-sd5600-t19/>